



© 2004 Lennox Industries, Inc.
Dallas, Texas USA

AIR CLEANERS/ FILTERS

504,887M
06/2004

HEALTHY CLIMATE®

HEPA BYPASS AIR FILTRATION SYSTEM

HOMEOWNERS MANUAL & DEALER INSTALLATION INSTRUCTIONS FOR LENNOX MODELS HEPA-20, HEPA-40, HEPA-60

Rules for Safe Installation and Operation

READ AND SAVE THESE INSTRUCTIONS!

Please read instructions before installing and using the HEPA Bypass Air Filtration System (HEPA system). This will help you obtain the full benefit of the HEPA system you have selected. It will also help you to avoid needless service costs.

1. Read this manual carefully. Failure to follow these rules and instructions could cause a malfunction of air filter or unsatisfactory service and could void your warranty.
2. Follow a regular service and maintenance schedule to ensure efficient operation.
3. For safety and optimized performance of your HEPA system, all installation and maintenance must be performed by a Lennox dealer. The installer should be made aware of your indoor air quality situation and be familiar with your heating, ventilation and air conditioning equipment.
4. Remove HEPA cartridge packing materials before initial start-up of this product.
 - a. Remove safety screws from HEPA filter access panel.
 - b. Unlatch the four retaining clips and lift off HEPA filter access panel.
 - c. Remove and discard the cardboard packing material between the HEPA cartridge and the filter access panel.
 - d. Ensure HEPA cartridge is installed and locked into place (brace the unit, press HEPA cartridge down and turn it clockwise to lock it into place.)
 - e. Replace the HEPA filter access panel and latch it with the four retaining clips.
 - f. Re-install safety screws into HEPA filter access panel.
5. High particulate distribution may occur during initial start-up of this product after installation or after scheduled filter changes. Individuals who are highly sensitive to airborne particulates should not be in the building and allow 24 hours of operation for removal of particulates from occupied spaces before re-entry.

Shipping and Packing List

Package 1 of 1 contains:

- 1 - HEPA System
- 1 - Complete Filter Set (Packed inside Unit)
- 1 - Homeowners IAQ Guide
- 1 - Warranty Certificate
- 1 - Installation Instructions (this manual)
- 1 - Registration Card

HEPA System Models

HEPA-20 (X2668) is designed to filter air up to a rate of 180 cfm

HEPA-40 (X2670) is designed to filter air up to a rate of 320 cfm

HEPA-60 (X2672) is designed to filter air up to a rate of 500 cfm

	<p>⚠ WARNING</p> <p>Electrical Shock Hazard.</p>
	<p>Can cause injury or death.</p> <p>Disconnect all electrical power supplies before servicing.</p> <p>Do not operate equipment without access panels in place</p>

<p>⚠ WARNING</p> <p>Risk of property damage, injury or death.</p>
<p>Installation, adjustments, alterations, service and maintenance must be performed by a Lennox dealer.</p>

<p>⚠ WARNING</p> <p>Risk of Carbon Monoxide Poisoning.</p>
<p>Can cause injury or death.</p> <p>Do not operate equipment without access panel in place. Operation of this equipment without all access panels in place may cause gas fumes from the heating system to be drawn into occupied spaces.</p>

Table of Contents

Rules for Safe Installation and Operation	1	Maintenance	9
Shipping and Packing List	1	Filter Change Schedule	9
Specifications	2	Filter Changing Guidelines	9
Introduction	2	Lennox Dealer Filter Change Instructions	10-11
General Information	3	Lennox Dealer Motor Assembly	
Product Application Guidelines	3	Replacement Instructions	11
Parts Identification	4	Electrical Diagram	12
Physical Dimensions of Units	5	Replacement Parts	12
Lennox Dealer Installation Instructions	6-8		
Operation	9		

Specifications

	HEPA-20	HEPA-40	HEPA-60
Nom. Air Flow @ 120VAC @ 0.0" E.S.P.	180 cfm	320 cfm	500 cfm
Weight (max - unpackaged)	25 lbs.	35 lbs.	40 lbs.
Supply Voltage	120 VAC	120 VAC	120 VAC
Nom. Measured Power Consumption	125 Watts	125 Watts	225 Watts
Motor Current Draw	1.0 amps, 60hz	1.0 amps, 60hz	1.8 amps, 60hz
Air Inlet Collar (max)	8"-round	10"-round	10"-round
Air Outlet Collar (max)	6"-round	8"-round	8"-round
Operating Temp. Range - Return air (°F)	30 to 95	30 to 95	30 to 95

HEPA filter efficiency = 99.97% @ 0.3 micron particles
 Ambient temperature range: -40°F to 130°F

Introduction

Congratulations! You will quickly realize that you have purchased a very effective air cleaning system. It incorporates state of the art HEPA (High Efficiency Particulate Air) technology.

Your Healthy Climate HEPA system comes with a limited warranty. With proper attention to its care and maintenance, you will receive optimum performance.

If your indoor air has abnormally high concentrations of particulates, the life span of the filter media may be shortened. Excessive particulates in the air will reduce the expected life of the HEPA filter. Under normal conditions the HEPA filter will last from two to five years.

The optional activated carbon canister has a finite limit as to the amount of odor or other gaseous volatile organic compounds (V.O.C.'s) that it can adsorb. The higher the concentrations, the shorter the expected life. Higher humidity may shorten the life of the carbon

canister. Under normal conditions, the carbon canister should last up to 6 months.

Initially, the HEPA filter's particulate removal efficiency improves with use. However, the air flow through the HEPA filter media will decrease, as dust builds up on the filter, thus lowering its ability to circulate and clean as much air as when it was new. If the air flow through your unit is noticeably reduced, you can inspect the carbon pre-filter and HEPA filter to see if they should be replaced. Replacement of the carbon pre-filter every 12 months will help extend the life of the HEPA filter.

Please contact your local Lennox dealer regarding replacement of filters, warranty information or if you have any questions or concerns about the performance of your HEPA system.

NOTE: This filtration system is an ADDITIONAL filter, and does NOT replace the existing air handler/furnace system filter.

General Information

Media Filters

Media filters strain particulates from the air. The filter media needs to have tiny holes to allow air to pass through, but not particulates. Filter types vary for all sorts of purposes. The most effective and proven filter media is HEPA. HEPA filter media is 99.97% efficient at capturing particles which are 0.3 micron in size or larger.

Inner Charcoal Filter/Carbon Canister

Carbon media is used to capture chemicals and odors, also referred to as V.O.C.'s. Chemicals and odors cannot be captured with media type filters. Activated carbon attracts chemicals and odors and holds them. If air passes through the carbon filter before particulates are removed, the surface of the carbon quickly gets covered with particulates, rendering it ineffective at capturing chemicals and odors. If particulates are removed from the air with a HEPA filter, virtually the entire surface area of the carbon can be used to capture chemicals and odors. This increases the efficiency and filter life of the inner charcoal filter.

Separate HEPA and Carbon Filters

HEPA and carbon filters have different life spans. It is important for a filtration system to keep the filter components independent from each other, so that the filter

that is dirty/saturated can be changed. This is more economical than a system where you need to throw out two or three filters when only one needs changing.

The HEPA System's 3 Stage Filtration Process

The 3 stage filtration process is used to create a very effective filtration system. Each filter is independent and can be changed individually.

- **Stage 1:** Carbon pre-filter - The inexpensive carbon pre-filter removes larger particulates from the air, thus prolonging the life of the HEPA filter.
- **Stage 2:** HEPA - The HEPA filter removes 99.97% of particulates 0.3 micron and larger. The cleaned air then passes through the third stage filter.
- **Stage 3:** Inner Charcoal Filter - The inner charcoal filter is 1/2 an inch thick to give it plenty of surface area for removing chemicals and odors from the air. This filter may be replaced by an optional heavy duty granular carbon canister available for maximum removal of chemicals and odors. The clean air is then reintroduced into the air you breathe.

Product Application Guidelines

Size of House vs. Air Changes per Hour

Model Unit	Size of House*							
	1,000 ft ² (8,000 ft ³)	1,200 ft ² (9,600 ft ³)	1,500 ft ² (12,00 ft ³)	1,800 ft ² (14,400 ft ³)	2,000 ft ² (16,000 ft ³)	2,500 ft ² (20,000 ft ³)	3,000 ft ² (24,000 ft ³)	3,500 ft ² (28,000 ft ³)
HEPA-20	1.35	1.13	0.9	--	--	--	--	--
HEPA-40	2.4	2.0	1.6	1.3	1.2	1.0	--	--
HEPA-60	3.8	3.1	2.5	2.1	1.9	1.5	1.3	1.1

* Chart based on homes with 8 ft. ceilings.

Notes:

- Industry experience indicates that one (1) air change per hour generally provides adequate air cleaning. Actual results will depend on multiple factors such as outdoor particulate levels, infiltration rate, indoor activities etc.
- The chart is based on an infiltration rate of 0.3 air changes per hour, which is typical for residential construction. Higher infiltration typically brings in more particulates and thus increases the air changes per hour needed for HEPA bypass filtration. Other particulate sources in the house will require higher air changes per hour.
- The chart is based on continuous operation of the HEPA system. If the HEPA system is cycled, the capacity of the filter needs to be increased. For example, if the HEPA system is "ON" only half the time, then the capacity of the unit needs to be doubled or additional units need to be installed.
- The more air changes per hour provided, the more effective a HEPA system will be. People with sensitivities may desire a higher number of air changes per hour for cleaner air.

Parts Identification

Cabinet Parts

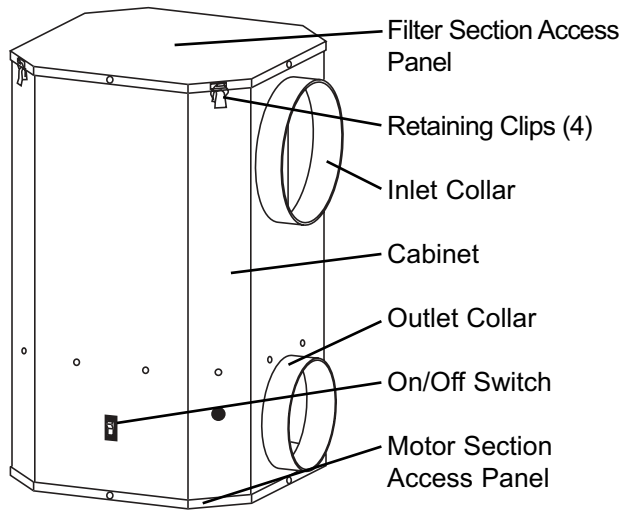

figure 1.

HEPA Cartridge Parts

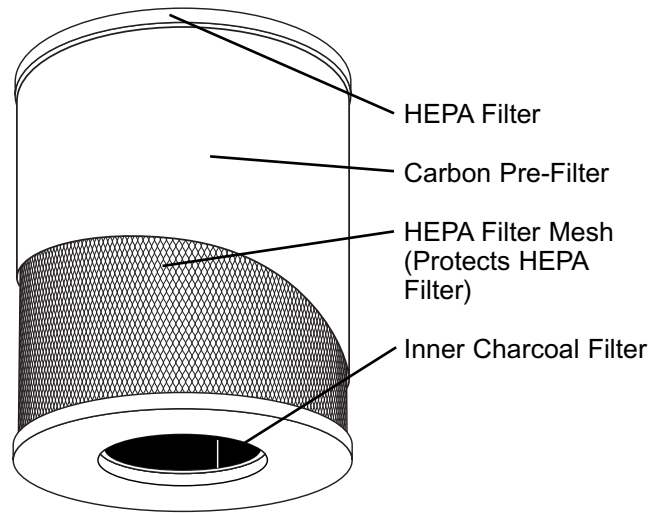

figure 2.

Inside Cabinet (Filter Section)

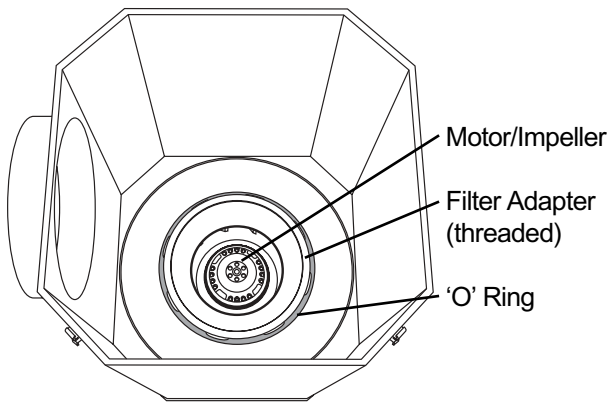
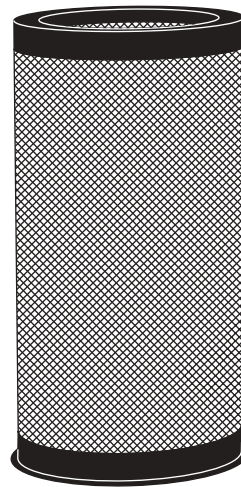

figure 3.

Optional Carbon Canister



For third stage heavy duty removal of chemicals and odors.

Located inside the HEPA filter.

Discard inner charcoal filter when using the optional carbon canister.

figure 4.

Physical Dimensions of Units

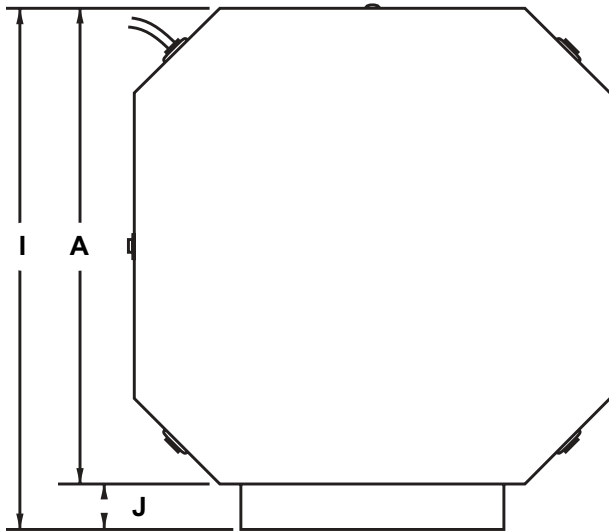
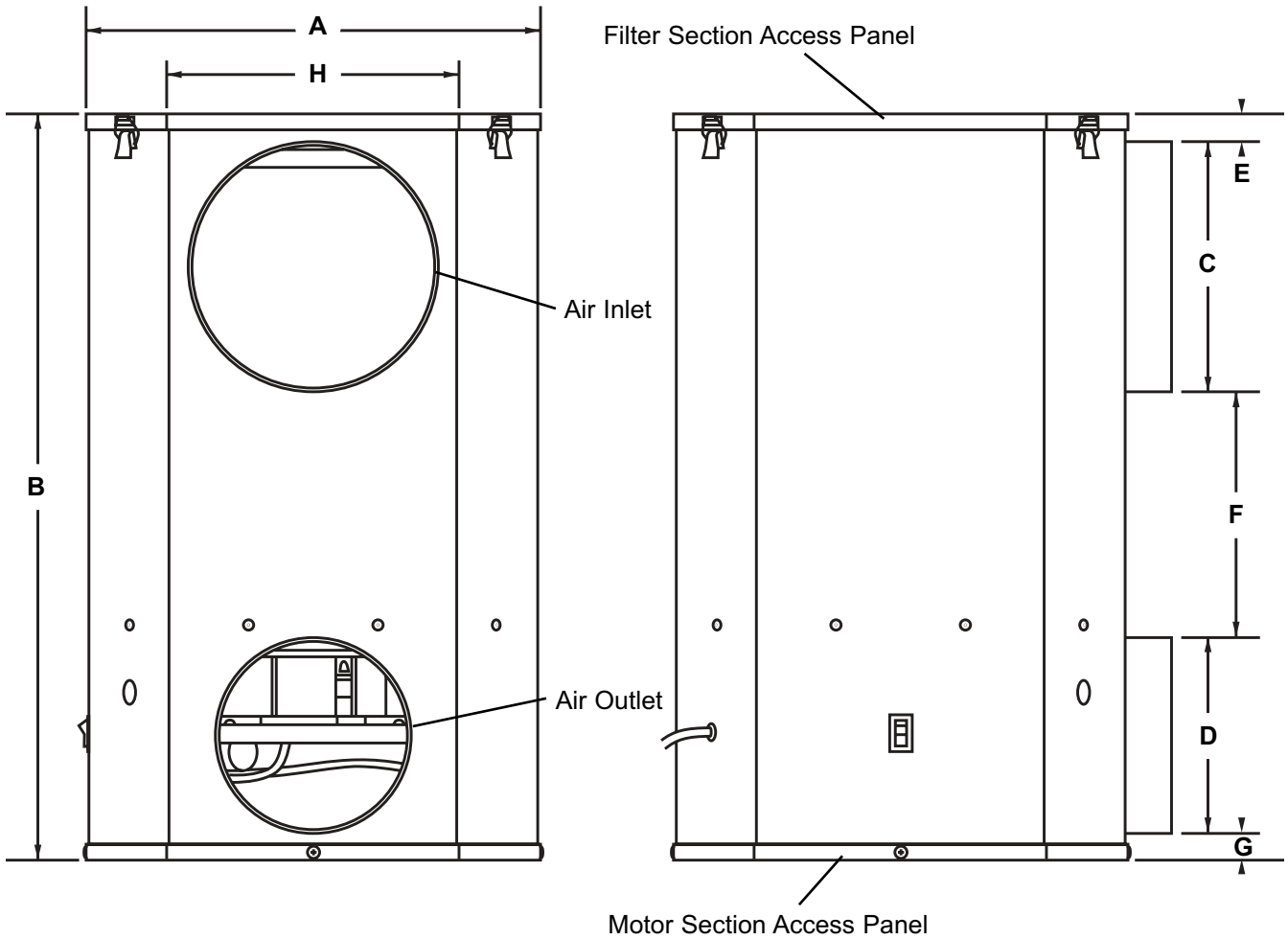

MODEL NO.	A	B	C	D	E
HEPA-20	14.1 (358)	18 (457)	8.0 (203)	6.0 (152)	1.0 (25)
HEPA-40	16.13 (410)	28.25 (718)	10.0 (254)	8.0 (203)	1.75 (44)
HEPA-60	16.13 (410)	28.25 (718)	10.0 (254)	8.0 (203)	1.75 (44-)
	F	G	H	I	J
HEPA-20	2.0 (51)	1.0 (25)	9.0 (229)	15.25 (387)	1.4 (36)
HEPA-40	6.5 (165)	1.0 (25)	11.0 (279)	17.875 (454)	1.875 (48)
HEPA-60	6.5 (165)	1.0 (25)	11.0 (279)	17.875 (545)	1.875 (48)

Dimensions in inches (mm)

figure 5.

Lennox Dealer Installation Instructions

Forced air handler/furnace systems:

The HEPA system should be installed as a bypass system, with part of the return ducted into the HEPA system. The filtered air is then rerouted back into the return air, and continues through the system to be heated/cooled.

Typical Return to Return Application

For homes with upflow forced air handler/furnace systems. (Air handler/furnace is shown in a typical basement. See Figure 6.)

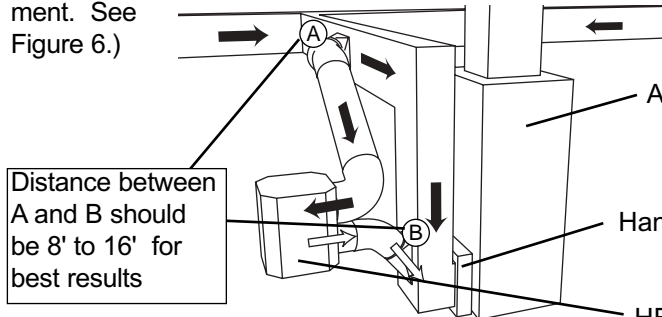

Figure 6.

Typical Return to Return Application

For homes with horizontal forced air handler/furnace systems. (Air handler/furnace is shown in an typical attic. See figure 7.)

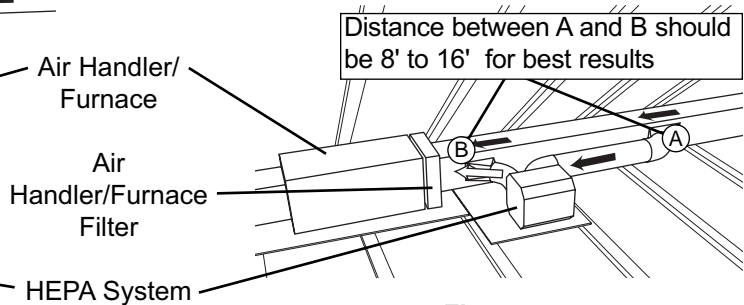

Figure 7.

NOTE: This filtration system is an **ADDITIONAL** filter, and does **NOT** replace the existing air handler/furnace system filter.

Preparation:

Here are some things to consider as you decide where to install the HEPA system.

Location:

- Make sure there is room to open the HEPA filter access panel for filter changes/inspections.
- Keep the HEPA system in a location where you can still access the air handler/furnace filter.
- Keep the HEPA system away from possible water damage.
- Vibration pads will reduce vibration for installations where the unit is placed on the floor.
- Install HEPA System on floor or suspended platform. If the unit is suspended, screws must not penetrate through the cabinet. Make sure that you have the proper chains/straps/joists and equipment to keep unit secure.

Inlet (Marked as 'Air In' on unit):

- Inlet ducts should be installed upstream of any humidifiers and be installed on the main return.
- Inlet duct should be installed at least 8 ft. away from the outlet duct on the main return.
- Use a 45 degree takeoff to draw air from the main return.

Outlet (Marked as 'Clean Air Out' on unit):

- Outlet duct should be installed as close to the air handler/furnace inlet as possible but not directly into the return air elbow of the main return.
- To reduce static pressure, install outlet with a 45 degree takeoff directly up-line from the return air elbow.
- If the unit is being installed independently of any other system, room diffusers are recommended to help distribute airflow evenly in the occupied space.

Ducting:

- If HEPA system is installed where inlet and outlet

collars face down, metal elbows must be connected to both inlet and outlet collars.

- Each connection must be sealed with aluminum tape or mastic, including all take offs.
- Installed duct runs should be as straight as possible (if the duct runs are too long, reduced CFM may result).
- If duct is exposed to unconditioned air, externally insulated flex duct is highly recommended.
- Externally insulated flex duct can also be used for noise reduction purposes
- For best indoor air quality, do not use ductboard or fiberglass inside of ducts.

Electricity:

- The unit must be plugged into a grounded 120V, 60Hz outlet.

Required Materials for Installation of Unit:

For Model: HEPA-20

- 8" diameter flex or rigid duct (as required)
- 6" diameter flex or rigid duct (as required)
- 8" diameter 45 degree takeoff
- 6" diameter 45 degree takeoff
- Aluminum tape or mastic
- Misc. hanging materials - field provided

For Models: HEPA-40 & HEPA-60

- 10" diameter flex or rigid duct (as required)
- 8" diameter flex or rigid duct (as required)
- 10" diameter 45 degree takeoff
- 8" diameter 45 degree takeoff
- Aluminum tape or mastic
- Misc. hanging materials - field provided

NOTE: Be sure to review 'Rules for Safe Installation and Operation' on page 1 of this document before start-up of this unit.

Lennox Dealer Installation Instructions

Forced air handler/furnace system with an HRV/ERV

This application provides filtration of all Outdoor Air (OA) that is brought into the home through the HRV/ERV, thus reducing the introduction of dust, pollen and mold from the outdoor air. For systems that have HRV/ERV units installed, we recommend ducting the 'fresh air' outlet from the HRV/ERV into the HEPA system. If the HRV/ERV CFM (cubic feet per minute) rating is lower than that of the HEPA system, an additional return needs to be installed into the HEPA system (See figure 8.) The output air from the HEPA system then needs to be installed into the main return of the air handler/furnace system.

Preparation:

Here are some things to consider as you decide where to install the HEPA system with an HRV/ERV.

Location:

- Make sure there is room to open the HEPA filter access panel for filter changes/inspections.
- Keep the HEPA system in a location where you can still access the air handler/furnace filter.
- Keep the HEPA system away from possible water damage
- Vibration pads will reduce vibration for installations where the unit is placed on the floor.
- Install HEPA System on floor or suspended platform. If the unit is suspended, screws must not penetrate through the cabinet. Make sure that you have the proper chains/straps/joists and equipment to keep unit secure.

Inlet (Marked as 'Air In' on unit):

- Most HRV/ERV systems will not move as much air as the HEPA system. For these systems, install an additional return from another treated air source into the HEPA system.
- If using an additional return duct, it should be installed upstream of any humidifiers. The fresh air outlet of the HRV/ERV should be "Y" connected to the additional return duct then connected to the inlet of the HEPA system.
- The additional return duct (if any) should be installed at least 8 ft. away from the outlet duct on the main return.
- Duct both the HRV/ERV and the additional return into the inlet of the HEPA system.

Outlet (Marked as 'Clean Air Out' on unit):

- Outlet duct should be installed as close to the air handler/furnace inlet as possible but not directly into the return air elbow of the main return.
- To reduce static pressure, install outlet with a 45 degree takeoff directly up-line from the return air elbow of air handler/furnace.

Ducting:

- If HEPA system is installed where inlet and outlet collars face down, metal elbows must be connected to both inlet and outlet collars.
- Each connection must be sealed with aluminum

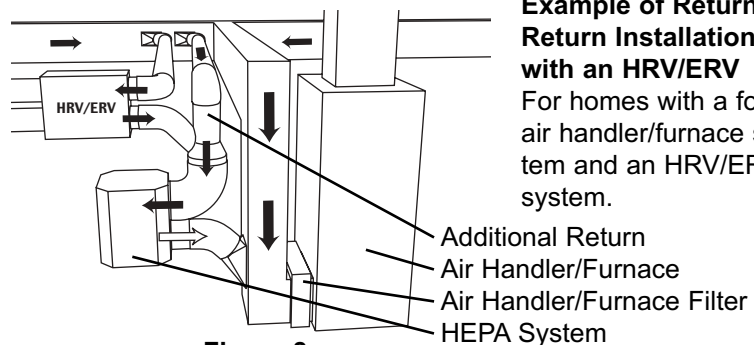

Figure 8.

NOTE: This filtration system is an **ADDITIONAL** filter, and does **NOT** replace the existing air handler/furnace system filter.

Example of Return to Return Installation with an HRV/ERV

For homes with a forced air handler/furnace system and an HRV/ERV system.

- tape or mastic, including all take offs.
- Installed duct runs should be as straight as possible (if the duct runs are too long, reduced CFM may result).
- If duct is exposed to unconditioned air, externally insulated flex duct is highly recommended.
- Externally insulated flex duct can also be used for noise reduction purposes
- For best indoor air quality, do not use ductboard or fiberglass inside of ducts.

Electricity:

- The unit must be plugged into a grounded 120V, 60Hz outlet.

Required Materials for Installation of Unit:

For Model: HEPA-20

- 8" diameter flex or rigid duct (as required)
- 6" diameter flex or rigid duct (as required)
- 6" diameter 45 degree takeoff
- Aluminum tape or mastic
- Misc. hanging materials - field provided

For Models: HEPA-40 & HEPA-60

- 10" diameter flex or rigid duct (as required)
- 8" diameter flex or rigid duct (as required)
- 10" diameter 45 degree takeoff
- 8" diameter 45 degree takeoff
- Aluminum tape or mastic
- Misc. hanging materials - field provided

NOTE: Be sure to review 'Rules for Safe Installation and Operation' on page 1 of this document before start-up of this unit.

Lennox Dealer Installation Instructions

Independent Operation:

The HEPA systems can be used independently of any other equipment! The inlet and outlet of the filtration system can be ducted into the same room to create a cleaner environment almost anywhere. The inlet or outlet can also be ducted elsewhere. The inlet and outlet should be installed on opposite sides of the room; however, this varies according to your specific needs.

Preparation:

Here are some things to consider as you decide where to install the HEPA system independently of other systems.

Location:

- Make sure there is room to open the HEPA filter access panel for filter changes/inspections.
- Keep the HEPA system away from possible water damage
- Vibration pads will reduce vibration for installations where the unit is placed on the floor.
- Install HEPA System on floor or suspended platform. If the unit is suspended, screws must not penetrate through the cabinet. Make sure that you have the proper chains/straps/joists and equipment to keep unit secure.

Inlet (Marked as 'Air In' on unit):

- Inlet ducts should be installed near the floor for optimum airflow (see figure 11). If space does not allow, then the inlet can be installed in the ceiling.
- Inlet duct should be installed at least 8 ft. away from the outlet duct on the main return.
- Inlet duct should be installed at opposite end of the room from the outlet duct(s) if in the same room.
- Diffusers are recommended to help distribute airflow evenly.

Outlet (Marked as 'Clean Air Out' on unit):

- Outlet(s) should be installed in the ceiling away from any other air inlet(s)
- Room diffusers are recommended to help distribute airflow evenly in the occupied space.

Ducting:

- If HEPA system is installed where inlet and outlet collars face down, metal elbows must be connected to both inlet and outlet collars.
- Each connection must be sealed with aluminum tape or mastic, including all vent connections.
- Installed duct runs should be as straight as possible (if the duct runs are too long, reduced CFM may result).
- If duct is exposed to unconditioned air, insulated flex duct is highly recommended.

Example of Single Room Stand Alone System Installation

For single rooms where increased filtration is desired such as a dedicated 'smoking room'.

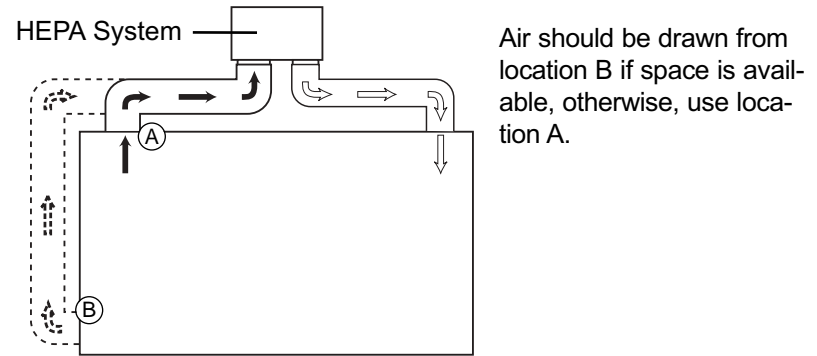

Figure 11.

- Externally insulated flex duct can also be used for noise reduction purposes
- For best indoor air quality, do not use ductboard or fiberglass inside of ducts.

Electricity:

- The unit must be plugged into a grounded 120V, 60Hz. outlet.

Required Materials for Installation of Unit:

For Model: HEPA-20

- 8" diameter flex or rigid duct (as required)
- 6" diameter flex or rigid duct (as required)
- 8" diameter vent
- 6" diameter vent
- Aluminum tape or mastic
- Misc. hanging materials - field provided

For Models: HEPA-40 & HEPA-60

- 10" diameter flex or rigid duct (as required)
- 8" diameter flex or rigid duct (as required)
- 10" diameter vent
- 8" diameter vent
- Aluminum tape or mastic
- Misc. hanging materials - field provided

NOTE: Be sure to review 'Rules for Safe Installation and Operation' on page 1 of this document before start-up of this unit.

Operation

1. Make sure that the unit is plugged into a grounded outlet (120 Volt, 60 Hz).
2. For optimum performance, the HEPA system should operate when the indoor air handler/furnace blower is on. An optional air handler/furnace blower interlock kit can be ordered for 'cycled' operation. (see Replacement Parts)
3. Turn the unit on by pressing the on/off switch to the '1' position. The switch should light up when the unit is on.
4. To turn the unit off, press the on/off switch to the '0' position. The switch light should turn off when the unit is off.

Maintenance

Proper care and maintenance of your HEPA system will ensure years of service. The unit must be turned off during service/maintenance or when filters are being changed.

It is recommended that gloves and a filtered breathing mask be worn during filter replacement.

	⚠ WARNING
	Electrical Shock Hazard.
	Can cause injury or death. Disconnect all electrical power supplies before servicing. Do not operate equipment without access panels in place

⚠ CAUTION
Risk of Sharp Edges Hazard.
Equipment sharp edges can cause injuries. Avoid grasping equipment edges without protective gloves.

Filter Change Schedule

Note: Note: Failure to properly maintain your HEPA system will decrease the efficiency and air flow.

Carbon Pre-Filter: 12 months

HEPA Filter: 2 to 5 years

Inner Charcoal Filter: 3 months

Optional Carbon Canister: 6 months

NOTE: Filter life is based on average air content. Some filters may need to be changed more often due to higher amounts of dust, humidity, or chemicals found in your ambient air. Additionally, people who are more sensitive to these air borne contaminants may desire more frequent filter changes.

Filter Changing Guidelines

Carbon Pre-Filter:

Dust and other large particles will collect on the carbon pre-filter over time. The color of the filter will change as particulates build up on the carbon pre-filter. Change the carbon pre-filter when you can see the particulate build up start to clog up the carbon pre-filter.

HEPA Filter:

As the HEPA filter captures particulates, it will darken over time. Replace the HEPA filter when it darkens to the level seen in example D.

A. New



B. Used



C. Used



D. Replace



Inner Charcoal Filter:

The inner charcoal filter will rarely look used. This filter captures odors and gasses, yet the filter's appearance will not change. When this filter has reached its maximum adsorbancy of odors and gasses, it will no longer work. Replace this filter when it no longer seems to capture odors, or every 3 months, whichever occurs first.

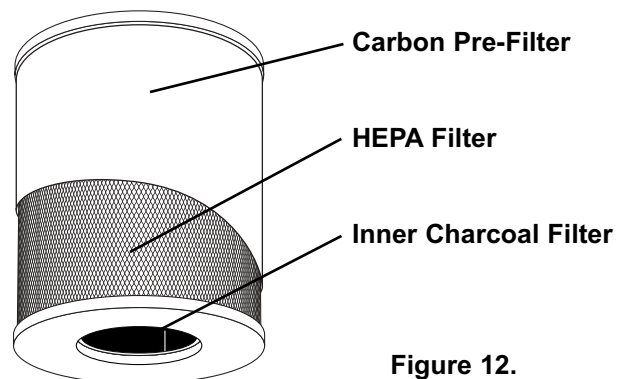



Figure 12.

Lennox Dealer Filter Change Instructions

	⚠ WARNING
	Electrical Shock Hazard.
	Can cause injury or death. Disconnect all electrical power supplies before servicing. Do not operate equipment without access panels in place

⚠ CAUTION
Risk of Sharp Edges Hazard.
Equipment sharp edges can cause injuries. Avoid grasping equipment edges without protective gloves.

It is recommended that gloves and a filtered breathing mask be worn during filter replacement to avoid breathing particulates (dust, mold, pollen, etc.) captured on the filter that become airborne during the filter(s) changeout.

The old filters should be wrapped and sealed in plastic bags immediately upon removal from the unit to avoid distributing particles throughout the house during the process of disposal.

1. Accessing the filters

- Remove safety screws from HEPA filter access panel.
- Unlatch the four retaining clips and lift off HEPA filter access panel.
- Bracing the unit so it does not move, turn the HEPA cartridge counter-clockwise and lift out.

2. Carbon Pre-Filter Replacement

- Locate the clips holding the carbon pre-filter in place. Remove them and pull the carbon pre-filter off.
NOTE: The carbon pre-filter may contain contaminants, remove it slowly to avoid releasing particles back into the air.
- Remove plastic shrink wrap from the new carbon pre-filter.
- Wrap the new carbon pre-filter around the HEPA filter, making sure that the ends overlap.
- Hook one end of the clip onto the overlapping section of carbon pre-filter as shown in figure 13.
- Press down on the hooked section while you pull it across, stretching the carbon pre-filter tighter. as shown in figure 14.
- Push down on the other end of the clip once the carbon pre-filter is stretched tight to lock the clip into place as shown in figure 15. Release clip, it should hold tight on both ends of the carbon pre-filter keeping it together.

- Repeat steps d through f with the other clips, spacing them evenly on the carbon pre-filter to give it even support.

3. Inner Charcoal Filter Replacement

- Look inside the HEPA cartridge to locate the two ends of the inner charcoal filter.
- Pull one end of the old inner charcoal filter in and bend it into a loose roll so it can be removed.
- Remove the inner charcoal filter from the HEPA cartridge.
- Remove plastic shrink wrap from the new inner charcoal filter.
- Unroll the inner charcoal filter and roll it up in the opposite direction (this makes the filter follow a more contoured profile against the inner HEPA filter surfaces and helps keep it in place), place the rolled inner charcoal filter inside the HEPA cartridge and gently unroll it until the ends 'butt' together and the filter is snug against the HEPA filter mesh.

4. HEPA Filter Replacement

- If replacing the HEPA filter with a new filter, discard old HEPA filter and use new when replacing the HEPA filter into the unit.

(continued on pg. 11)

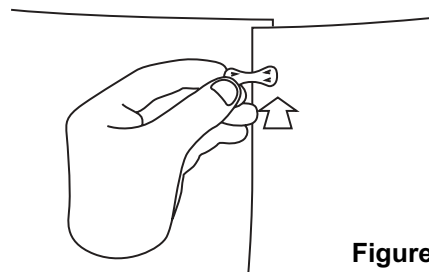

Figure 13.

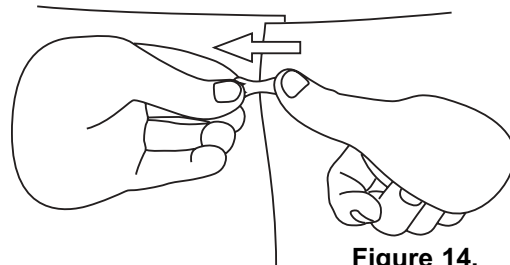

Figure 14.

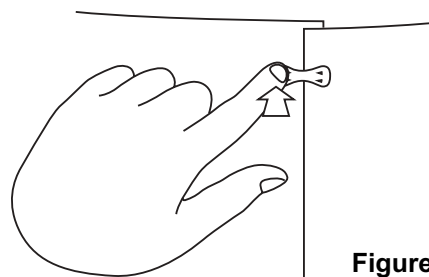

Figure 15.

Lennox Dealer Filter Change Instructions

- b. With each HEPA replacement filter, a new 'o' ring is provided. The old one is removed by pinching it between two fingers and pulling it off the collar on the blower deck.
- c. Discard old 'o' ring.
- d. Place the new 'o' ring onto the collar and slide it down to the base of the blower deck.

5. Optional Carbon Canister

- a. Remove old carbon canister (if installed) by pulling it out from the inside of the HEPA filter.
- b. If replacing an inner charcoal filter with the carbon canister, remove inner charcoal filter by following the steps a. to c. in section 3.
- c. Remove the plastic shrink wrap from the new carbon canister.
- d. Slide the carbon canister into the HEPA cartridge, smaller, tapered end first. The carbon canister should slide all the way in until the metal edges at

the base meet the HEPA filter.

- e. Support the carbon canister with your fingers so it does not slide out when replacing the HEPA cartridge assembly into the unit.

6. Installing the HEPA Filter Cartridge

- a. With the filters changed or inspected, all 3 filters are ready to be placed back into the unit. Place the HEPA cartridge gently into the unit (if a carbon canister is being used, take care not to let it slide out as it is heavy and could damage the unit)
- b. When the HEPA cartridge is in place, brace the unit, press down and turn it clockwise to lock it into place.
- c. Replace the HEPA filter access panel and latch it with the four retaining clips.
- d. Re-install safety screws into HEPA filter access panel.
- e. Plug the unit back into a power outlet and turn it on.

Lennox Dealer Motor Assembly Replacement Instructions

	⚠ WARNING
	Electrical Shock Hazard.
	Can cause injury or death.
	Disconnect all electrical power supplies before servicing.
	Do no operate equipment without access panels in place
	Do not use this fan with any solid-state speed control device

⚠ CAUTION
Risk of Sharp Edges Hazard.
Equipment sharp edges can cause injuries.
Avoid grasping equipment edges without protective gloves.

1. Accessing the motor assembly

- a. Turn the unit off and unplug it from any electrical source before opening the cabinet.
- b. To remove the motor section access panel, remove the four screws on the panel, and lift off panel.

2. Removing the old motor assembly

- a. Disconnect all four motor wires from switch, ground post and capacitor.
- b. Disconnect the two white wires from the capacitor.
- c. Separate the motor from the motor mount by removing the four screws found in figure 16.
- d. Slide the motor out from under the motor mount to remove it from the unit.

3. Installing the new motor assembly

- a. Slide the new motor into the motor mount making sure that the wires go through the smaller hole offset from the center of the bracket.
- b. Secure the new motor to the motor mount with the four screws removed in step 2c.
- d. Connect the wires as follows:
 - Blue wire from motor to the on/off switch.
 - Yellow/green wire from motor to the ground post.
 - Brown wire from the motor to a capacitor post.
 - Black wire from the motor to the other capacitor post.
 - White wire from the on/off switch to the capacitor via the black wire piggyback post.
 - White wire from the power cord to the capacitor via the other white wire's piggyback post.

4. Closing the unit

- a. Replace the motor section access panel and secure it with the eight screws removed in step 1b.
- b. Plug the unit into it's electrical source and turn it on.

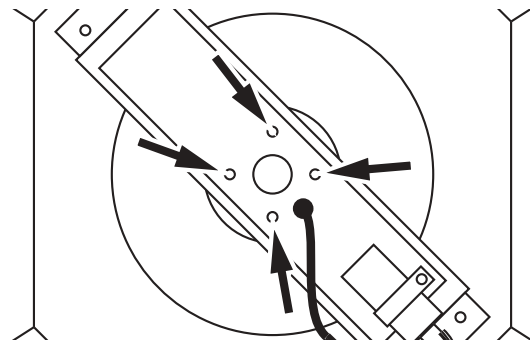

Figure 16.

Electrical Diagram

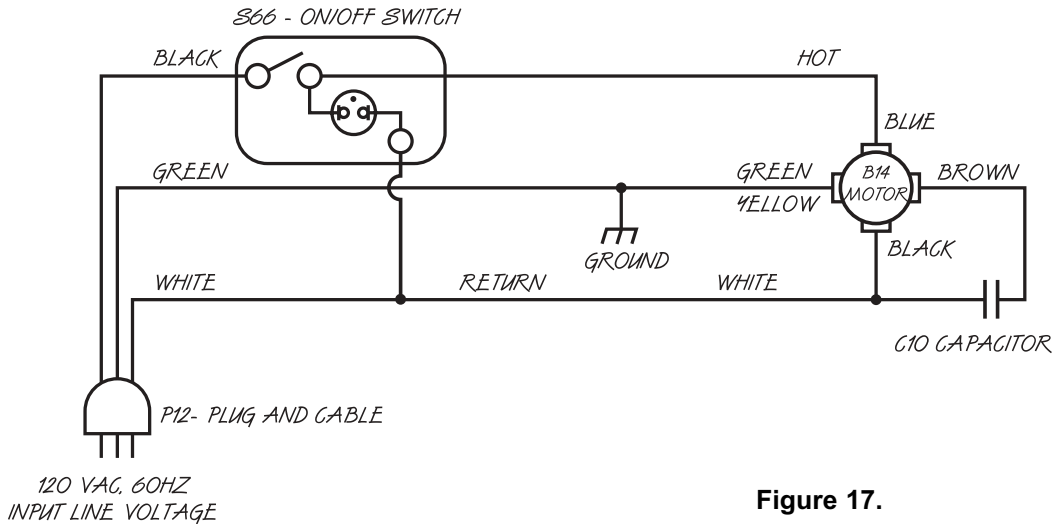

Figure 17.

Replacement Parts

Replacement Part	HEPA-20	HEPA-40	HEPA-60
Complete Assembly	X2668	X2670	X2672
Motor Assembly	X2669	X2669	X2671
HEPA Filter Cartridge w/O-Ring	92X17	92X10	92X10
Carbon Pre-Filter	X4137	X4138	X4138
Inner Charcoal Filter	X2678	92X09	92X09
Carbon Canister	94X98	98X75	98X75
Optional Blower Interlock (24V relay)	X2680	X2680	X2680

Use this unit only in the manner intended by the manufacturer. If you have questions, contact Lennox Industries.

Contact your local Lennox dealer to order replacement parts.
For the Lennox dealer near you, dial 1-800-9 LENNOX or visit us at www.lennox.com